

Interfacing the V-Stamp to a Telephone Line

This application note describes how to connect the V-Stamp to a telephone line, allowing it to be used in voice response, security, medical, and remote monitoring applications.

Introduction

Before the V-Stamp can be used in a telephone-based application, it must be properly interfaced to the telephone network. This requires a Data Access Arrangement (DAA) circuit, which must also comply with federally-mandated (FCC Part 68) regulations. The proper use of the DAA helps ensure the end-user's safety, and maintains the integrity of the telephone network.

Implementation

Two circuits will be shown. The first utilizes a Xecom (www.cermetek.com) XE0068 telephone DAA, which provides the interface between the V-Stamp and telephone network. This circuit is ideal for low production quantity applications because the DAA is already FCC Part 68 registered. The PCB layout should employ power and ground planes to minimize coupling of switching noise into the audio path.

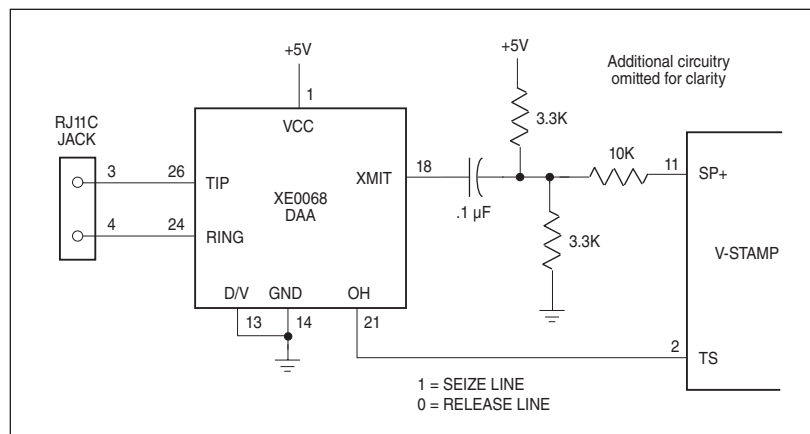

The second circuit is a lower cost implementation using a Xecom XE056J telephone DAA. This circuit is well suited for high volume applications due to the significantly lower cost DAA. The DAA is not FCC registered, however, so the product utilizing this circuit must be approved and certified by the FCC.

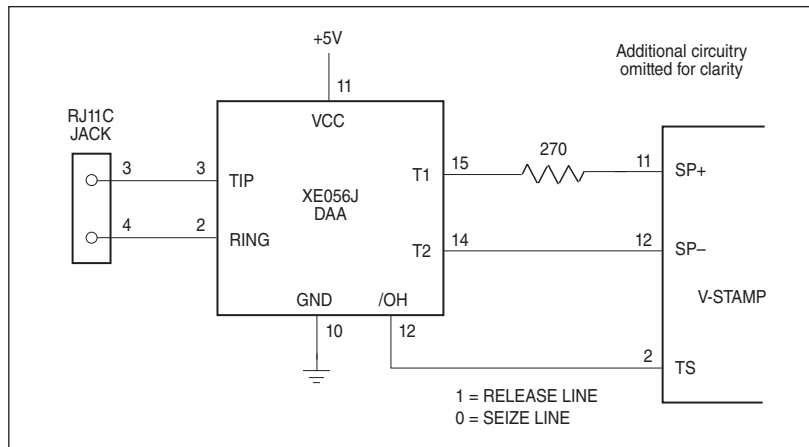

In both circuits, the V-Stamp's Talk Status (TS) pin is used to control the on/off hook status of the telephone line. Before any voice data and/or dialing tones can be issued, the line must be seized, or taken off-hook. This can be done by controlling the state of the TS pin with the RC8660 "2k" and "3k" commands.